



## Technical Information

### Purmelt HKP 26



## PUR Hotmelt Adhesive for Edgebanding Straightline

### Characteristics

- Reactive hotmelt adhesive system based on polyurethane
- Fast setting
- High initial strength
- Chemical cross-linking within few days
- Forms an insoluble, thermoset film
- Very high heat resistance (> 150 °C/> 302 °F) and cold flexibility
- Excellent water resistance
- Produces tight joints

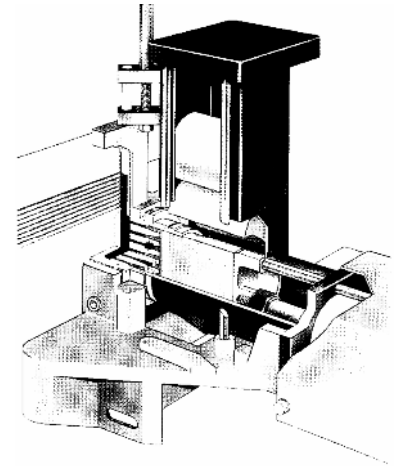

### Fields of application

- Edgebanding in HolzHer cartridge equipment as from feedrates of 10 m/min
  - Edging material: solid wood, veneer, melamine, polyester, HPL\*, PVC\*, ABS\*, PP\*
- \*Suitability depends on the individual characteristics of the edging material and how it is primed.  
In case of thick edges pre-tests should be carried out for suitability.*

### Technical data

Softening point (Kofler):	approx. 100 °C (212 °F)
Viscosity (Brookfield):	approx. 25 000 mPa·s / 150 °C (302 °F)
Curing time to final strength:	2 - 5 days
Heat resistance:	> 150 °C (302 °F)

*tested with 0.6 mm oak veneer using the DORUS method of increasing temperature*

### Instructions for use

Recommended working temperature: approx. 150 °C (302 °F)

Since the product will cure when it is exposed to moisture, storage and application must be done under dry conditions. For this reason, the product is delivered in airtight containers.

### Cleaning

Flushing the system with *Purmelt Cleaner 2* periodically or prior to changing to an alternative reactive hot melt will reduce internal build-up of adhesive residue. Application devices such as wheels and rolls that expose reactive adhesive to the air should be thoroughly flushed at the end of a production run or at anytime when there is build-up and gelling. Cured PUR hot melt can only be removed by softening with an appropriate solvent such as N-ethyl-pyrrolidone (NEP) and then using a non-abrasive scraper.

Strictly follow the instructions of the machine manufacturer.

### Delivery form

Cartridges

### Storage

Store in a cool, dry place in the unopened original container for up to 9 months.

### Labelling

The safety datasheet should be respected!

## Safety

The product contains diphenylmethanediisocyanate. Even if the product is applied within the range of the recommended working temperature, the diisocyanate has a detectable vapour pressure. When the recommended working temperature is considerably exceeded, hazardous decomposition products may be formed in the application unit. Therefore, measures to draw off the vapours need to be taken, e.g. through the provision of extraction equipment. In case of skin contact with the hotmelt, do not try to remove the adhesive from the skin by force. Consult a doctor. Observe the material safety data sheet.

09/2007

*The information provided herein, especially recommendations for the usage and applications of our products, is based on our knowledge and experience. Due to different material used as well as to varying working conditions beyond our control we strictly recommend to carry out intensive trials to test the suitability of our products with regards to the required process and applications. We do not accept any liability with regards to the above information or with regard to any verbal recommendation, except for cases where we are liable of gross negligence or false intention.*